



## Ceiling Loudspeaker System



## CS100 Installation Guide



WARNING - TO REDUCE RISK OF FIRE OR ELECTRICAL SHOCK, DO NOT EXPOSE THIS EQUIPMENT TO RAIN OR MOISTURE.

NO USER-SERVICEABLE PARTS INSIDE.  
REFER SERVICING TO QUALIFIED PERSONNEL.

## IMPORTANT SAFETY INSTRUCTIONS!

### PLEASE READ THEM BEFORE OPERATING THIS EQUIPMENT.

#### General:

1. Read these instructions.
2. Keep these instructions.
3. Heed all warnings.
4. Follow all instructions.
5. Warning: To reduce risk of fire or electrical shock, do not expose this equipment to rain or moisture. This unit is capable of producing high sound pressure levels. Continued exposure to high sound pressure levels can cause permanent hearing impairment or loss. User caution is advised and ear protection is recommended when playing at high volumes.
6. Only use attachments/accessories specified by the manufacturer.

#### Installation:

7. Install in accordance with the manufacturer's instructions.
8. When mounting the Ceiling Loudspeaker System to a building structure it is important to follow all of the local building/construction codes. Make sure the ceiling structural members can support a total weight of five times the weight of the Ceiling Loudspeaker System.
9. Do not install near any heat sources such as radiators, heat registers, stoves, or other equipment (including amplifiers) that produce heat.
10. Do not use this equipment near water.
11. Do not expose this equipment to dripping or splashing and ensure that no objects filled with liquids, such as vases, are placed on the equipment.

#### Care of Equipment:

12. Clean only with a dry cloth.
13. Do not permit objects or liquids of any kind to be pushed, spilled and/or fall into the equipment through enclosure openings.

#### Repair of Equipment:

14. Refer all servicing to qualified service personnel. Servicing is required when the equipment has been damaged in any way, liquid has been spilled or objects have fallen into the equipment, the equipment has been exposed to rain or moisture, does not operate normally, or has been dropped.
15. Do not attempt to service beyond that described in the operating instructions. All other service should be referred to qualified service personnel.
16. When replacement parts are required, be sure the service technician has used replacement parts specified by McIntosh or have the same characteristics as the original part. Unauthorized substitutions may result in fire, electric shock, or other hazards.
17. Upon completion of any service or repairs to this product, ask the service technician to perform safety checks to determine that the product is in proper operating condition.

## Thank You

Your decision to own this McIntosh CS100 Ceiling Loudspeaker System ranks you at the very top among discriminating music listeners. You now have "The Best." The McIntosh dedication to "Quality," is assurance that you will receive many years of musical enjoyment from this unit. Please take a short time to read the information in this manual. We want you to be as familiar as possible with all the features and functions of your new McIntosh.

## Please Take A Moment

The serial number, purchase date and McIntosh Dealer name are important to you for possible insurance claim or future service. The spaces below have been provided for you to record that information:

Serial Number: \_\_\_\_\_

Purchase Date: \_\_\_\_\_

Dealer Name: \_\_\_\_\_

## Technical Assistance

If at any time you have questions about your McIntosh product, contact your McIntosh Dealer who is familiar with your McIntosh equipment and any other brands that may be part of your system. If you or your Dealer wish additional help concerning a suspected problem, you can receive technical assistance for all McIntosh products at:

McIntosh Laboratory, Inc.  
2 Chambers Street  
Binghamton, New York 13903  
Phone: 607-723-1545  
Fax: 607-724-0549

## Customer Service

If it is determined that your McIntosh product is in need of repair, you can return it to your Dealer. You can also return it to the McIntosh Laboratory Service Department. For assistance on factory repair return procedure, contact the McIntosh Service Department at:

McIntosh Laboratory, Inc.  
2 Chambers Street  
Binghamton, New York 13903  
Phone: 607-723-3515  
Fax: 607-723-1917

Copyright 2007 © by McIntosh Laboratory, Inc.

## Table of Contents

Safety Instructions .....	2
Thank You and Please Take a Moment.....	2
Technical Assistance and Customer Service .....	2
Table of Contents .....	3
Important Information .....	3
Performance Features .....	3
Dimensions .....	4
Installation .....	4
Installing the Loudspeaker .....	5
Warranty .....	7
Specifications.....	8

## Important Information

1. Loudspeaker Cables of adequate size are important to ensure there will be no significant power loss or heating. Cable size is specified in Gauge numbers or AWG (American Wire Gauge). The smaller the Gauge number, the larger the wire size:
  - If the Loudspeaker Cables are 25 feet (7.62m) or less, use at least 18 Gauge (AWG) wire size or larger.
  - If the Loudspeaker Cables are 50 feet (38.1m) or less, use at least 14 Gauge (AWG) wire size or larger.
  - If the Loudspeaker Cables are 100 feet (76.2m) or less, use at least 12 Gauge (AWG) wire size or larger.The Loudspeaker Connection Terminals can accept up to 12 Gauge (AWG) wire.
2. For additional connection information, refer to the owner's manual(s) for any component(s) connected to the CS100 Loudspeaker System.
3. When the CS100 Loudspeaker System is driven by more than one amplifier, the output levels of the different amplifiers connected to the Loudspeaker System must be adjusted to achieve a proper balance between the low and the midrange/high frequencies reproduced. This adjustment is best achieved through the use of audio test equipment operated by a qualified installer.
4. When the symbol illustrated here is located on the product or on the packaging, it indicates the product must not be disposed of with your other household waste. Instead, it is your responsibility to dispose of your waste equipment by handing it over to a designated collection point for the recycling of waste electrical and electronic equipment. The separate collection and recycling of your waste equipment at the time of disposal will help to conserve natural resources and ensure that it is recycled in a manner that protects human health and the environ-



ment. For more information about where you can drop off your waste equipment for recycling, please contact your local city office, your household waste disposal service or the McIntosh Dealer where you purchased the product.

## Performance Features

### • Patented Technology

The McIntosh CS100 Loudspeaker System uses the patented<sup>1</sup> unique Loudspeaker System design allowing the baffle to be rotated up to 357° to direct the sound toward the listener to maintain proper sound stage.

### • Boundary Compensation

The Boundary Compensation Circuitry in the crossover network enhances placement flexibility when the CS100 is located near sidewalls or corners.

### • Unique driver orientation

The 3-way Loudspeaker System uses no more space than a typical 2-way System. When positioned near the rear or side walls of a room, the CS100 wide dispersion sound characteristics can be directed towards the side or rear of the seating position for direct-radiating surround sound or reflected off the side or rear wall to create a diffuse sound field surround.

### • High Power Handling

The CS100 Loudspeaker Elements and Crossover Components allow for use with amplifiers up to 200 watts.

### • Versatile Operation

In addition to the regular connections, the CS100 Loudspeaker System provides separate connections for Bi-Amplification hookups.

### • Gold Plated Input Connectors

The CS100 input connectors are gold plated for superior corrosion resistance and high electrical conductivity.

<sup>1</sup> U.S. Patent number 7171013



## Dimensions

The following dimensions can assist in determining the best location for the CS100 Loudspeaker System.

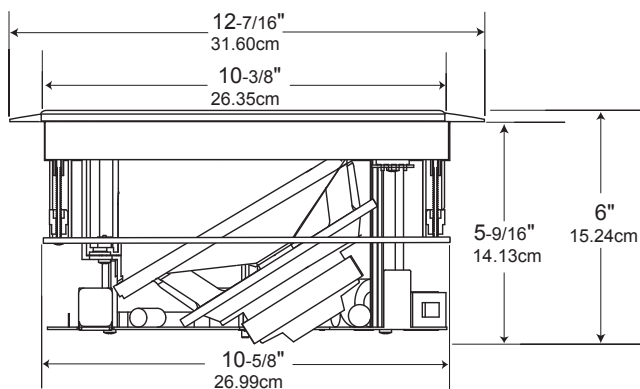

## Installation Overview

The CS100 Ceiling Loudspeaker System is designed to mount into the ceiling of a typical room. Before choosing the location in the ceiling for the CS100, it is important to read “Location in the Room” for the best possible performance. When mounting the Ceiling Loudspeaker System to a building structure, it is important to follow all of the local building/construction codes. Make sure the ceiling structural members can support a weight of 45 pounds (five times the net weight) for each CS100. The ceiling thickness should be a minimum of 3/8 inch (0.95cm) for secure mounting of the CS100.

It is recommended that the Professionals at your McIntosh Dealer, who are skilled in all aspects of installation and operation, install the CS100 Loudspeaker System and any associated audio equipment.

## Location in the Room

Due to the nature of installing the CS100 Ceiling Loudspeaker System, it is important to consider any possible future changes likely to be made to the room, like furniture placement, before deciding on the locations for the CS100s.

The tweeter and midrange baffle of the Loudspeaker have been angled to deliver accurate on-axis response to the listening position.

The baffle must be properly positioned to deliver the best sound. Refer to the dispersion pattern in figure 1.

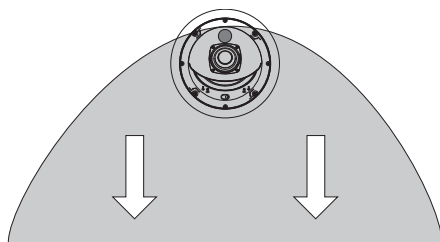

Figure 1

## For use in a Music System

For optimum results from a music system, place the Loudspeakers on either side of the listening area and rotate the Loudspeaker’s baffle toward the listening area. Refer to figure 2. Use multiple pairs for optimum coverage in large rooms.

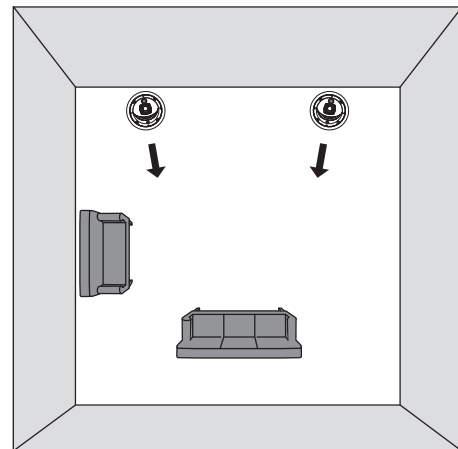

Figure 2

## For use in a Home Theater

When using the CS100 as a front or main Loudspeaker keep the Loudspeakers as close to the front wall as possible. Ideally, the center Loudspeaker should be located on the same plane as the television or projection screen. The left and right Loudspeakers should be positioned no farther in than the outside of the screen or monitor. Refer to figures 3 and 4.

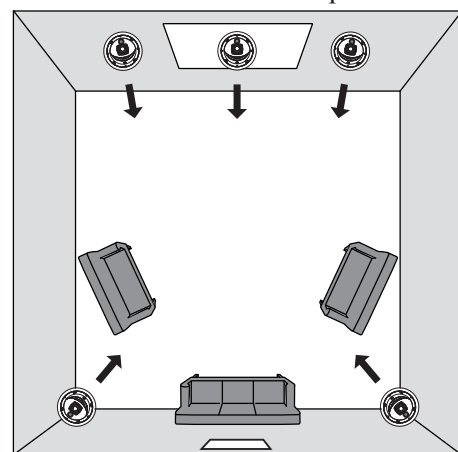

Figure 3

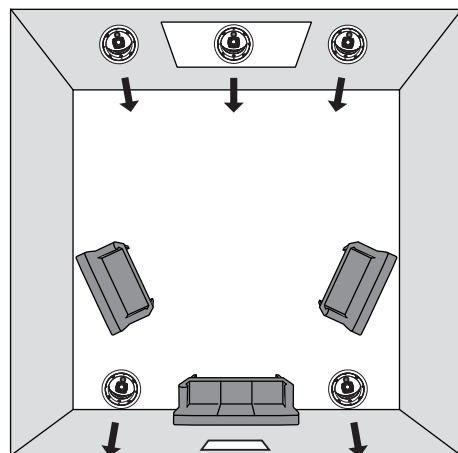

Figure 4

When using the CS100 as a surround Loudspeaker, the CS100 can be used as either a direct or diffuse surround Loudspeaker. For direct operation, direct the Loudspeaker baffle toward the listening area as illustrated in figure 3. For a diffused surround sound operation, direct the Loudspeaker baffle toward a back wall or corner as illustrated in figure 4.



## Painting the Loudspeaker

The CS100 Ceiling Loudspeaker System is primed and may be painted before or after installation.

### The Loudspeaker Frame:

1. Insert the supplied paint shield into the frame of the Loudspeaker. Refer to figure 5.
2. Paint the frame with light coats, to help prevent excessive paint buildup and “runs” on the frame.
3. After the paint has dried, use the finger pulls to remove the paint shield.

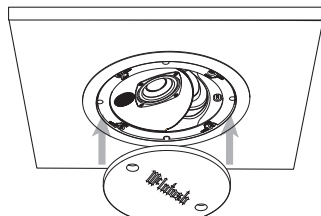

Figure 5

### The Loudspeaker Grille:

1. Carefully remove the cloth from the inside of the grille. Set it aside in a clean location.
2. Paint the grille with very light coats, to help prevent paint from filling the holes in the grille.
3. After the paint is dry, reinstall the previously removed grille cloth.

## Preparing for Installation

In determining the CS100 Loudspeaker location, it is important to keep away from any heating/cooling ductwork, electrical wiring and plumbing that may be located in the ceiling between the joists. The CS100 is designed for indoor use only. Indoor rooms with high humidity levels should be avoided; i.e. an indoor swimming pool area, directly above a bathtub/shower/jacuzzi/sauna, etc.

When mounting the CS100 Ceiling Loudspeaker System to a building structure, it is important to follow all of the local building/construction codes. Make sure the ceiling structural members can support a weight of five times the total weight of the Ceiling Loudspeaker System.

When the CS100 will be installed into a room under construction, it is advisable to install the optional McIntosh RK100 Rough-In Kit Bracket into the joists. The bracket provides a rigid mounting location for the Loudspeaker, a secure tie off point for the hookup cable and allows for easier finishing of the ceiling surface.

If the RK100 Rough-In Kit Bracket is used, install the Loudspeaker hookup cable from the location of the Audio Component(s) (Power Amplifier) to the bracket making sure to leave about 24 inches (60.96cm) of cable after the cable tie point. This will make for easier connection of the cable to the Loudspeaker and allow for rotation of the Loudspeaker after installation into the ceiling. Also refer to “Installing the Loudspeaker” step 5.

## Installing the Loudspeaker

Follow the instructions below for installation using appropriate tools. If the optional RK100 Rough-In Kit Bracket has been previously installed, go directly to step 6:

1. Place the supplied Hole Cutting Template to the desired mounting location in the ceiling and trace the outside edge of the template onto the mounting surface. Refer to figures 5 and 6.
2. In the center of the circle just drawn on the mounting surface, make a small pilot hole. Insert a long wire (with an insulated handle) into the opening and verify there are no objects located in the ceiling where the Loudspeaker will be installed. Refer to figure 7.

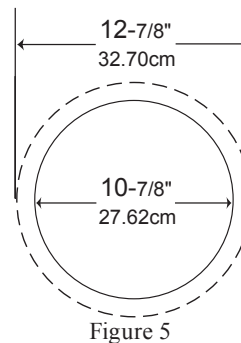

Figure 5

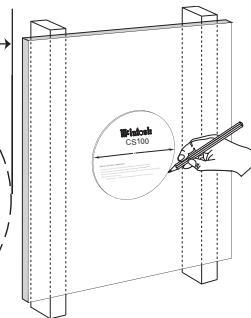

Figure 6

*Note: Check to make sure the thickness of the ceiling material is at least 3/8 inch (0.95cm), as this is necessary for the Loudspeaker's clamping devices to provide a secure mounting.*

3. Cut out and remove the piece of ceiling material.
4. Install the Loudspeaker hookup cable from the location of the Audio Component(s) (Power Amplifier) to the opening. Using a suitable securing device, attach the cable inside the ceiling making sure to leave about 24 inches (60.96cm) of cable.

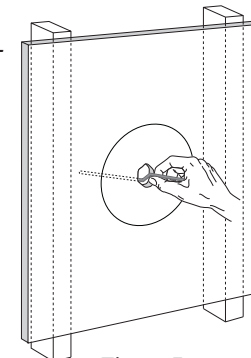

Figure 7

*Note: This will make for easier connection of the cable to the Loudspeaker and allow for rotation of the Loudspeaker after installation.*

5. Install into the ceiling opening nonflammable sound absorbing material (such as fiberglass) to reduce sound leakage into other areas and reduce acoustical standing waves/resonances. If there already is paper or aluminum backed fiberglass located in the ceiling, remove the backing where it would come into contact with the rear of the Loudspeaker. Refer to figure 8.

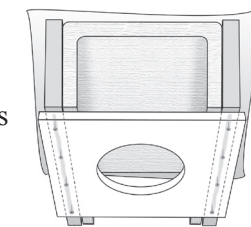

Figure 8

### Installing the Loudspeaker, con't

6. Prepare the Loudspeaker hookup cables by carefully remove sufficient insulation from the cable ends and twist the strands together, refer to figures 9, 10 & 11.

*Note: If desired, the twisted ends can be tinned with solder to keep the strands together.*

7. Connect the prepared hookup cables to the Full Range Terminals being careful to observe the correct polarities. Refer to figure 12.

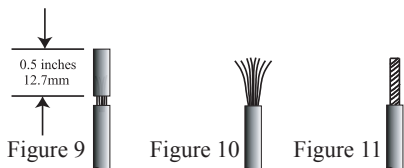

*Note: If the CS100 is to be used with two Power Amplifiers (BIAMP), connect the cable from the Low Frequency Amplifier to the Low Frequency Terminals. Connect the cable from the High Frequency Amplifier to the High Frequency Terminals. Move the Jumper Selector from the "Normal" position over to the "Biamp" position.*

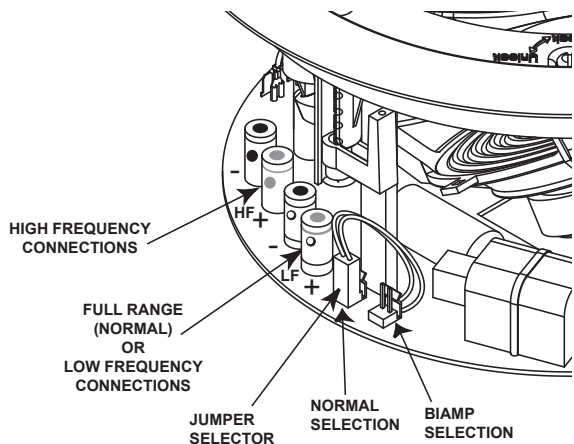

Figure 12

8. Install the Loudspeaker into the cutout opening and tighten the four Phillips mounting screws. The clamping arms will pivot into position and secure the Loudspeaker to the mounting surface; do not over tighten the screws. Refer to figures 13 and 14.

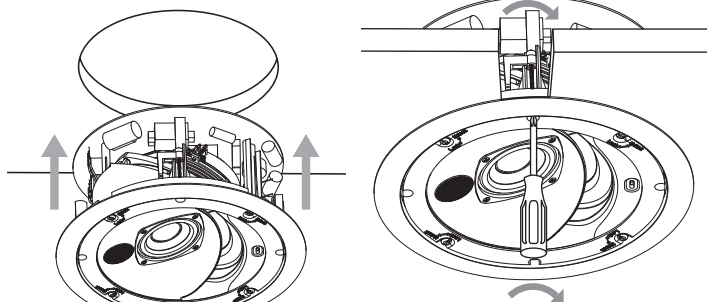

Figure 13

Figure 14

9. To aim the Midrange/Tweeter Acoustic Output to the desired area, first rotate the four flat head screws to the unlock position. Then grasp and rotate the Midrange/Tweeter Acoustic Reflector being careful not to damage the Loudspeaker Drivers. Then re-lock the four flat head screws to secure the new position. Refer to figures 15 and 16.

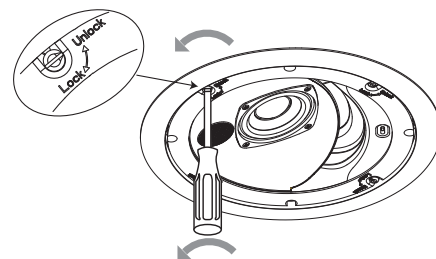

Figure 15

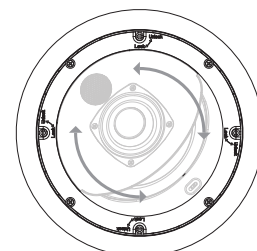

Figure 16

10. Place the Boundary Compensation Switch in the correct position according to the information in figure 18. Refer to figures 17 and 18.

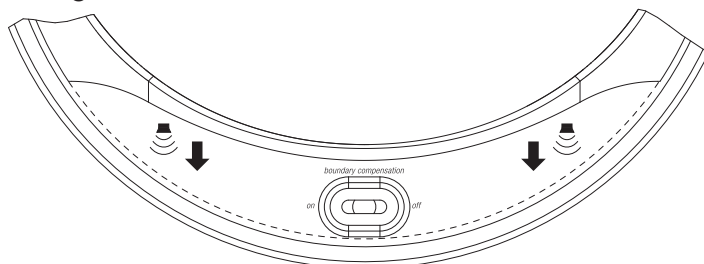
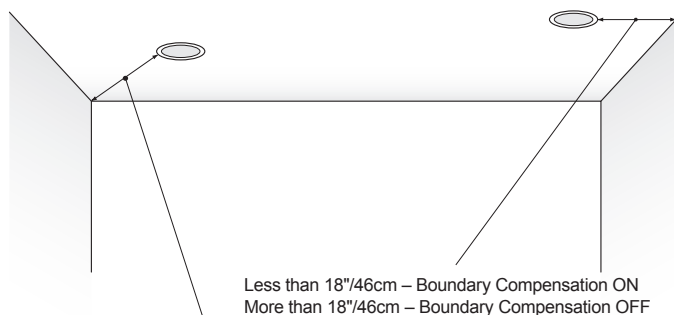

Figure 17



Less than 24"/61cm – Boundary Compensation ON  
More than 24"/61cm – Boundary Compensation OFF

11. Insert the Loudspeaker Grille into the baffle slots by applying gentle pressure along the circumference of the grille.



## LOUDSPEAKER PRODUCTS FIVE YEAR LIMITED WARRANTY

Welcome to the family of McIntosh owners. This is the Warranty for your new McIntosh Loudspeaker Product (the "Speaker"). Your Speaker has been designed to give many years of trouble-free performance. Nonetheless, failures do sometimes occur even with equipment as well-built as McIntosh's. Therefore, please read this Warranty carefully, because it contains rights, as well as limitations, exclusions, and obligations, which in the event of such a failure may be very important to you. If after reading it thoroughly, you have any questions about

the Warranty, please do not hesitate to write or telephone McIntosh at the address or phone number shown on the back of this warranty. Please note that this is the only Warranty which McIntosh provides for your Speaker, and that no one, including your dealer, has any authority to either modify or expand upon this Warranty. If your dealer has offered or made any warranties or representations concerning the Speaker which differ from those contained in this Warranty, they are strictly between you and the dealer, and will neither be binding upon McIntosh nor change any of the provisions in this Warranty.

### Scope and Duration of Warranty

Subject to the terms and conditions stated below, McIntosh Laboratory, Inc. ("McIntosh") warrants to the original owner that this Speaker shall be free from defects in workmanship or materials for a term of five (5) years from the date when it was purchased from an Authorized McIntosh Dealer.

### Limitations on Persons and Speakers Covered by this Warranty

This Warranty and all rights provided here under are limited to the original owner. In the event that the original owner transfers ownership of the Speaker prior to expiration of the five-(5) year term, this Warranty shall terminate in its entirety upon the date of such transfer. In addition, McIntosh does not warrant in any way Speakers which are purchased from anyone who is not an Authorized McIntosh Dealer, or which have had their Serial Numbers altered or defaced. Therefore this Warranty is void and inapplicable if this Speaker has been purchased from someone other than an Authorized McIntosh Dealer, or has had its original Serial Numbers altered or defaced.

### Important Note Regarding Mail, Telephone, and Online Purchases

In order to insure the highest possible level of customer satisfaction, Authorized McIntosh Dealers are expressly prohibited from selling new McIntosh Speakers by mail, telephone, or the internet. Therefore, if you purchased the Speaker which is accompanied by this Warranty by mail, by telephone, or over the internet, your seller was not an Authorized McIntosh Dealer, and/or the Speaker you purchased is used and you are not its original owner. In any such event, this Warranty is void, as provided in the preceding paragraph, and any warranties, service agreements, or other representations of any kind which you may have received from your seller are binding solely upon your seller and not upon McIntosh. If you have been misled in any way on this subject, you should make immediate inquiry of your seller.

### Geographical Limitations

This Warranty has been included with a McIntosh Speaker that is designed, intended to be sold and used only within the United States and Canada. Accordingly, this Warranty only applies to Speakers which are purchased in the United States or Canada, and only applies while such Speakers are used in the United States or Canada. Speakers purchased outside the United States or Canada, and failures occurring outside the United States or Canada, are not covered by this Warranty.

### What McIntosh will do under the Warranty

In the event of any defect covered by this Warranty, McIntosh shall without charge provide all parts, materials, and labor necessary to restore the Speaker to its original specifications. After repair, McIntosh shall return the Speaker to its owner at the owner's expense. In the alternative, McIntosh may at its sole option either replace the Speaker without charge, or if replacement is not commercially practicable or repair or replacement cannot be accomplished within a reasonable time, McIntosh may refund the purchase price of the Speaker, subject where appropriate to reasonable depreciation for actual use in accordance with applicable laws, in full satisfaction of its warranty obligations. McIntosh or its Authorized Service Agency will undertake to complete the repair and return of the Speaker as soon as circumstances permit, unless prevented by causes beyond their reasonable control.

### Limitations on McIntosh's Obligations under the Warranty

McIntosh's sole Obligation under this Warranty shall be to repair or replace the Speaker, or at its option refund the purchase price, as provided for hereinabove. McIntosh

does not warrant against, nor shall it be liable for, any of the following: removal or installation charges; shipping expenses either to or from McIntosh or its Authorized Service Agency; loss of use; property damage of any kind; or other incidental or consequential damages or losses of any kind.

*Note: Some states do not allow exclusion or limitation of consequential damages, so the foregoing exclusions may not apply to you.*

### Parts and Occurrences that are not Covered by the Warranty

This Warranty does not cover any of the following: (a) glass panels, cabinetry, trim, or other appearance items (except where they are defective at the time of original sale and the Speaker is delivered for repair within the first thirty (30) days thereafter); (b) batteries, or damage to the Speaker caused by failure of batteries; (c) failures arising from accident, catastrophe, misuse, neglect, or failure to properly connect and operate the Speaker in accordance with the accompanying instructions; (d) failures arising from improper installation or removal of the Speaker; or (e) failures arising from any tampering, alteration, or attempted servicing of the Speaker by anyone other than McIntosh or an Authorized McIntosh Service Agency; and McIntosh shall have no liability or obligation of any kind with respect to any of the foregoing types of failures.

### What the Owner must do to obtain service under this Warranty

To obtain service under this Warranty, the owner must at the owner's expense arrange for any necessary de-installation of the Speaker, and deliver or ship the Speaker to McIntosh at the address below, or to an Authorized McIntosh Service Agency, properly packaged, prepaid, and insured at the owner's expense. In addition, the owner must provide evidence that the Speaker is at the time of delivery within the scope of his Warranty, by either having completed and submitted to McIntosh on a timely basis the accompanying Warranty Registration Card, or by including the original sales receipt (photocopies are not acceptable) with the Speaker when it is delivered for repair.

### What the Owner must Pay For

As noted above, the owner must pay any expense of removing the Speaker from its installation, and must pay any expenses for delivery of the Speaker to McIntosh or the Authorized McIntosh Service Agency. Upon return of the Speaker to the owner following repair, it shall be the owner's responsibility to pay for the shipping charges incurred in return of the Speaker, as well as to arrange and pay for any re-installation which may be required. In addition, it shall be the owner's obligation to pay for any repairs made to any Speaker for which the owner has neither completed and submitted the Warranty Registration Card at the time of purchase nor included the original sales receipt with the Speaker when delivered for service, at McIntosh's or its Authorized Service Agency's then-current repair rates.

### How to learn where the nearest Authorized McIntosh Service Agency is, or obtain answers to other questions concerning this Warranty

In order to learn the name and address of the nearest Authorized McIntosh Service Agency, obtain instructions for shipment of a covered Speaker to McIntosh, or obtain the answers to any other questions you may have concerning this Warranty, you may telephone McIntosh's Customer Service Department between the hours of 9:00 a.m. and 4:30 p.m. Eastern Time, Monday through Friday, at 888-979-3737 (607-723-3512) or write to McIntosh at 2 Chambers Street, Binghamton, New York 13903-2699, Attention: Customer Service Department.

*Note: This Warranty gives you specific legal rights, and you may also have other rights which vary from state to state.*



### Specifications

---

#### System Driver Complement

One 8 inch DCD™ Copolymer Cone Woofer  
One 3-1/2 inch Neo Copolymer Cone Midrange  
One 1 inch VF® Aluminum Dome Tweeters

#### Impedance

8 ohms Nominal

#### Frequency Response

48Hz - 22kHz (±3dB)

#### Sensitivity

89dB (2.83V/1m equivalent)

#### Crossover Frequencies

400Hz  
3,000Hz

#### Power Handling

200 Watts Maximum

### General Specifications

---

#### Operating Temperature

41 to 95°F  
5 to 35°C

#### Operating Humidity

30 to 85%

#### Overall Dimensions

Width is 12-7/16 inches (31.60cm)  
Height is 12- 7/16 inches (31.60cm)  
Depth is 6 inches (15.24cm)

#### Weight

8.3 pounds (3.76 kg) net, 10.5 pounds (4.76 kg) in shipping carton

#### Shipping Carton Dimensions

Width is 13-3/4 inches (34.9cm)  
Depth is 13-3/4 inches (34.9cm)  
Height is 9-1/4 inches (23.5cm)



McIntosh Laboratory, Inc.  
2 Chambers Street  
Binghamton, NY 13903

The continuous improvement of its products is the policy of McIntosh Laboratory Incorporated who reserves the right to improve design without notice.

Printed in the U.S.A.